



Ansaldo Sistemi Industriali

POWER  
ELECTRONICS  
FOR INDUSTRIAL  
APPLICATIONS

**HIGH-PERFORMANCE  
MEDIUM VOLTAGE  
VARIABLE FREQUENCY  
DRIVES**





Yesterday



Today

## Taking your manufacturing processes to new frontiers

In an increasingly competitive world, innovating your production process can make a difference. Our development and applications engineers have the expertise in power control design to tailor solutions that often exceed customer expectations. Our Medium Voltage (MV) drives are designed to improve the overall flexibility and efficiency of the plant, achieving significant, long-term cost savings by reducing energy consumption.

### Pioneers in Power Control & Power Electronics

Ansaldo Sistemi Industriali (ASI) can trace its experience in power control and power electronics back to its original factory *Stabilimento Elettrotecnico* founded in 1899. Back then it was just a secondary switching device. Today, power electronics are a fundamental part of manufacturing and automation processes offering important advantages in terms of flexibility and reduced energy consumption. For over 110 years we have developed, manufactured and supplied electric drives and power control systems for numerous applications worldwide.

We have been present at every stage in the growing development of power electronics and, in many cases, have been at the forefront in pushing this technology to new levels of performance. In the early 1990's we were pioneers in high speed technology for gas compression applications. Today, our R&D activities are taking this technology even further, developing power electronic solutions for high-power, high-speed applications; continuously improving safety, reliability and overall efficiency. Exploring new areas of application allow us to increase the performance of our drives, providing our customers with highly reliable state-of-the-art components.

Improving safety, reliability and overall efficiency

Over 110 years

Pioneers in high speed technology



# The right fit for the right performance

From their inception our converter system designs have been focused on compliance with customer requirements including: dynamic performance consistent with the most demanding process needs, user-friendly interface, high reliability as well as ease of maintenance and repair; offering optimum power quality, near unity power factor and more than 98% drive efficiency.

## Up to 100 MW

Our engineering capabilities allow us to configure and supply power conversion systems up to 100 MW based on our standard drive technology.



**H-Series (Silcovert TH, Silcovert NH)**

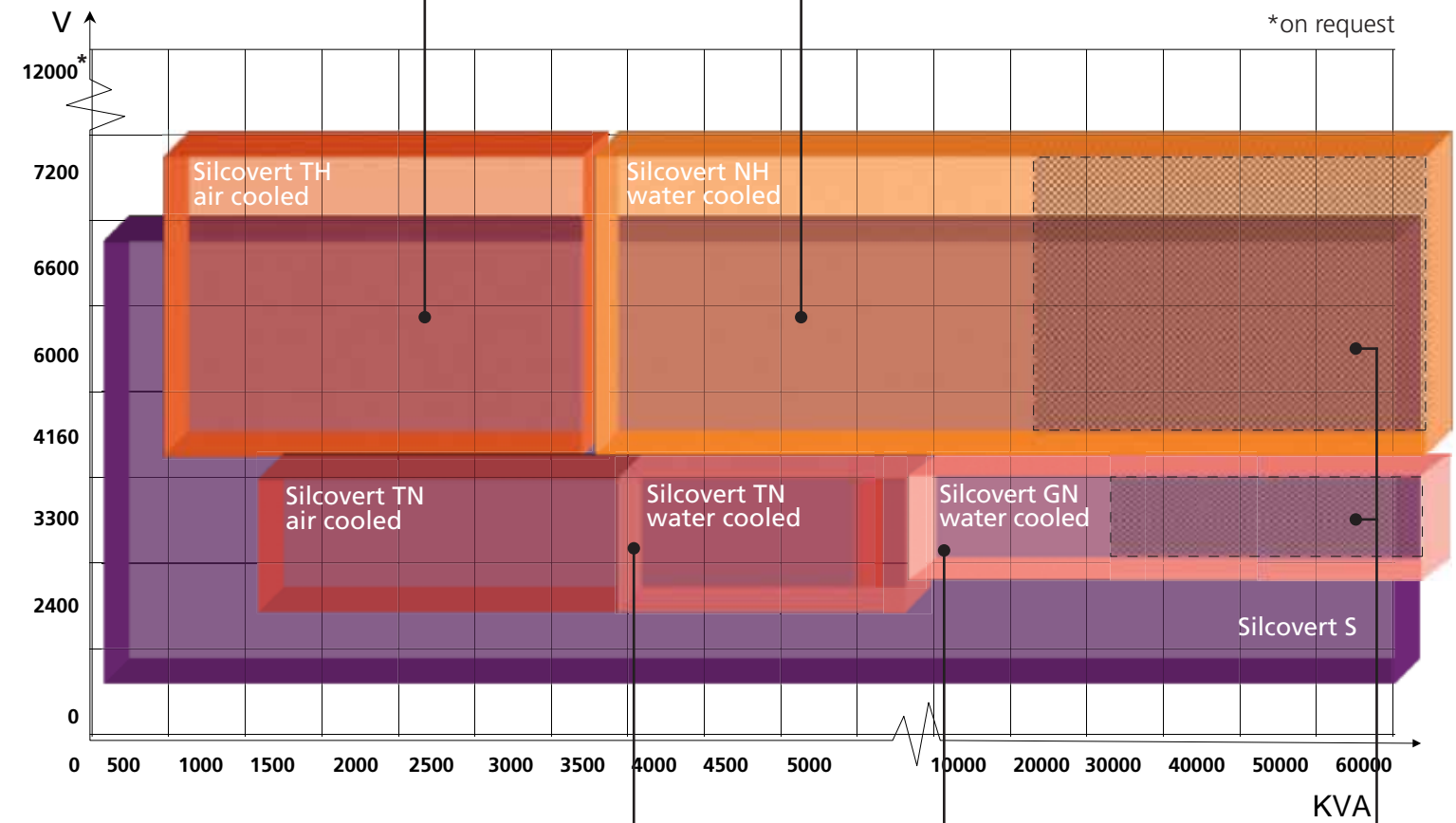

**N-Series (Silcovert TN, Silcovert GN)**



# N-Series

Silcovert TN 2.4 kV; 3.3 kV  
 Silcovert GN 3.3 kV



TN - IGBT

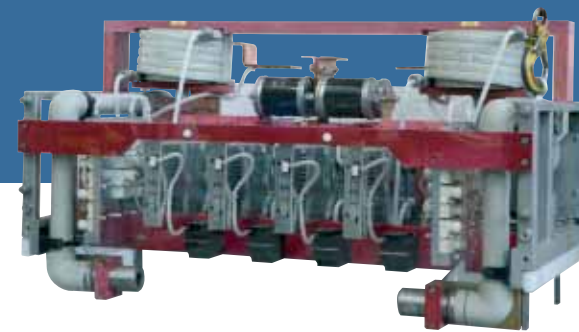

GN - IGCT

# H-Series

Silcovert TH 4.16 kV; 6 kV; 6.6 kV; 7.2 kV;  
 Silcovert NH 4.16 kV; 6 kV; 6.6 kV; 7.2 kV; 12 kV on request

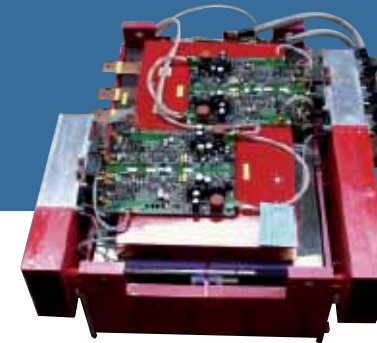

TH - IGBT

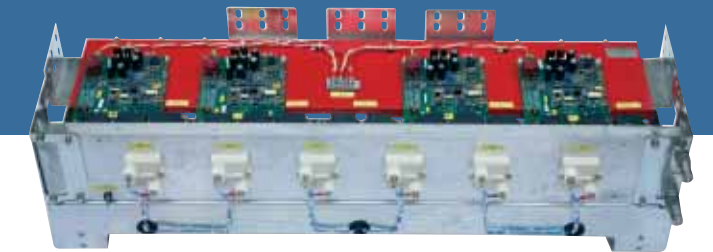

NH - IGBT

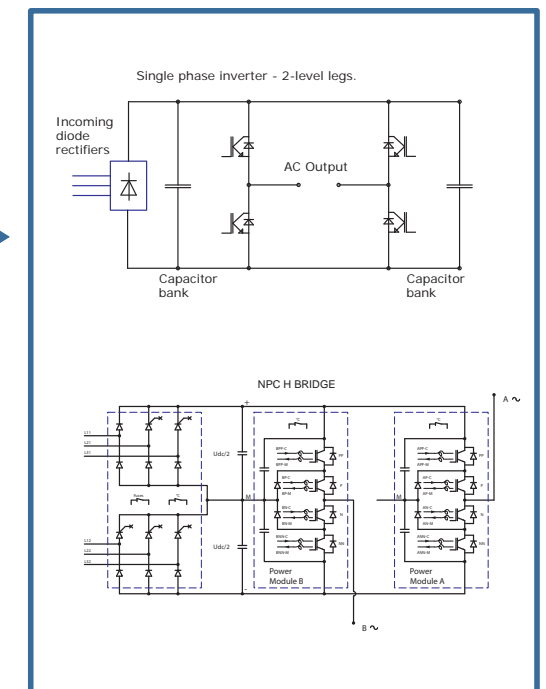
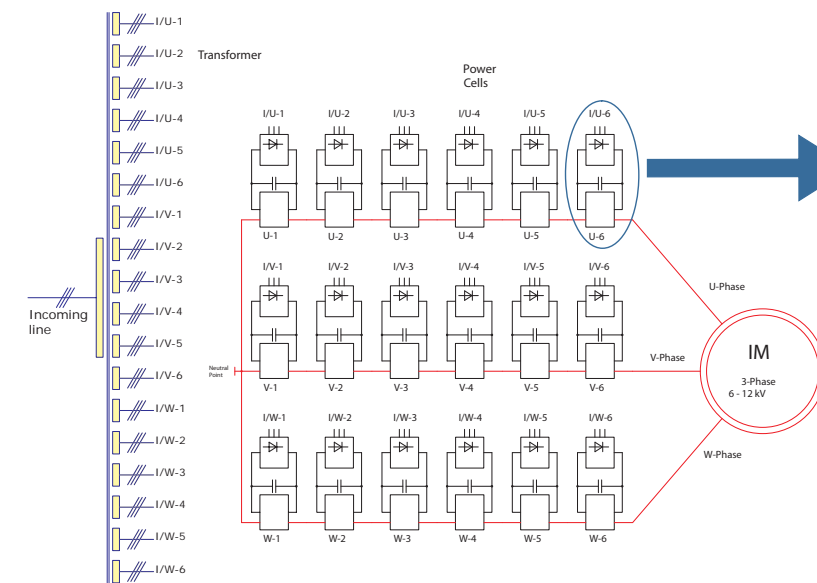
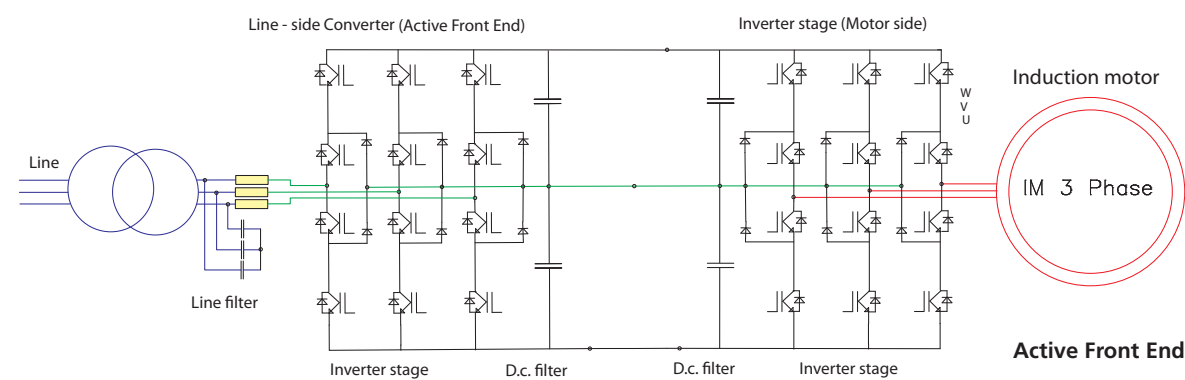
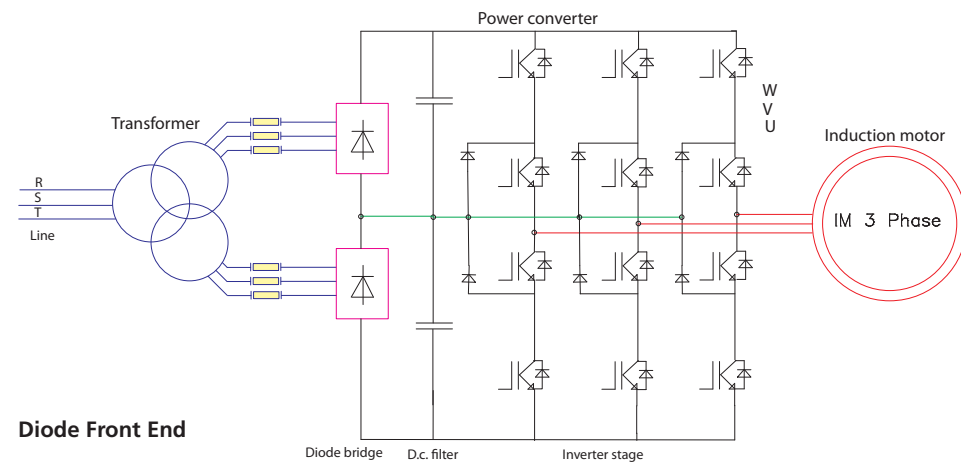

The right performance starts

with the right choice of power system



Our family of MV Drives all use our state-of-the-art control system. This system allows perfect control of the whole process and enhances the efficiency in your plant. The system is based on a high performance 32 bit CPU that allows distributed control and processing plus network configuration that seamlessly integrates into any automation system.

### Common Control Platform

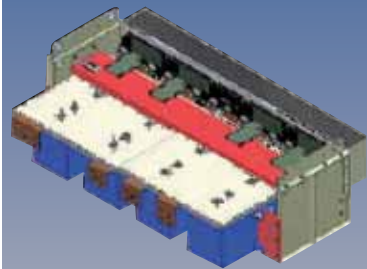

Providing the right power solution for an application helps guarantee optimum performance. We have a full range of modular solutions that allow the selection of a 12-pulse, 24-pulse, or 36-pulse passive diode rectifier (DFE). Our N-series drives can also be configured for Active Front End (AFE) operation. By placing modules in parallel we can rapidly configure the drive to match power needs. We provide the optimum solution to meet process requirements.

### Standard Power Modules

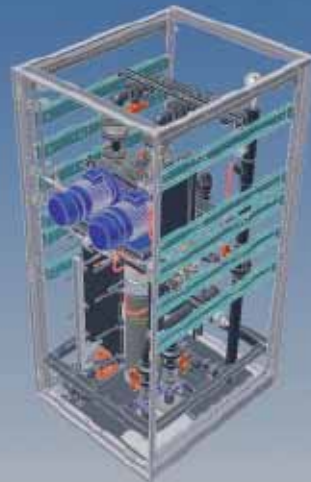

The drives can be air or water-cooled. Water cooled solutions are available with redundant capability for optimal plant integration. The water-cooled system significantly reduces ventilation and air conditioning costs for high power applications. Deionised water (mixed with glycol in low temperature applications) passes through the heat sinks. The internal closed-loop liquid circuit is cooled by a secondary heat exchanger, either liquid to air or liquid to water. For lower power ratings, where converter generated heat is less significant, we use forced air-cooling. Our water cooled drives are ideal for industries like Metals and Cement where air-borne dust and pollutants can compromise long-term performance. The closed-circuit water cooling keeps the inside of the drive free from harmful agents.

### Cooling Options

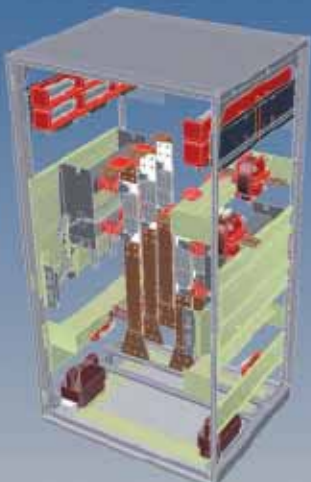

Ansaldo Sistemi Industriali equips its drives with a variety of auxiliaries according to application requirements. These can include:  
Switchgear - Designed for maximum plant safety  
Transformers - Our TH drives have an intrinsically integrated transformer. Other drives can be provided with either integrated or separate transformer to meet plant requirements.  
Harmonic filters - As a standard our drives do not require Harmonic filters. However, filters can be provided for particularly weak networks where the risk of disturbance is quite high.

### Wide Range of Auxiliaries

## ...and highly reliable standard components

Flexible arrangement of all conversion system components, a high degree of power module and component standardization and different cooling options permit us to configure the right solution for even the most demanding customer requirements.

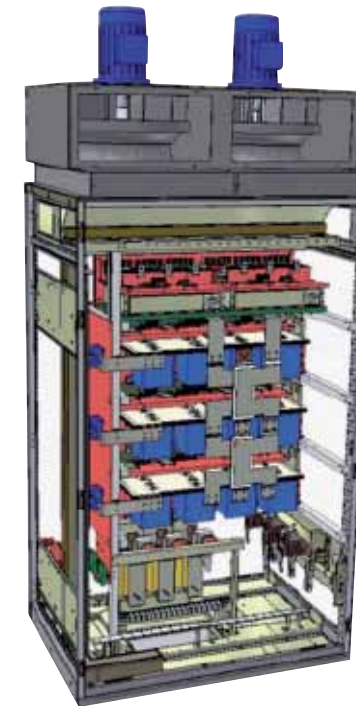

Air cooled inverter unit



Water cooled inverter unit

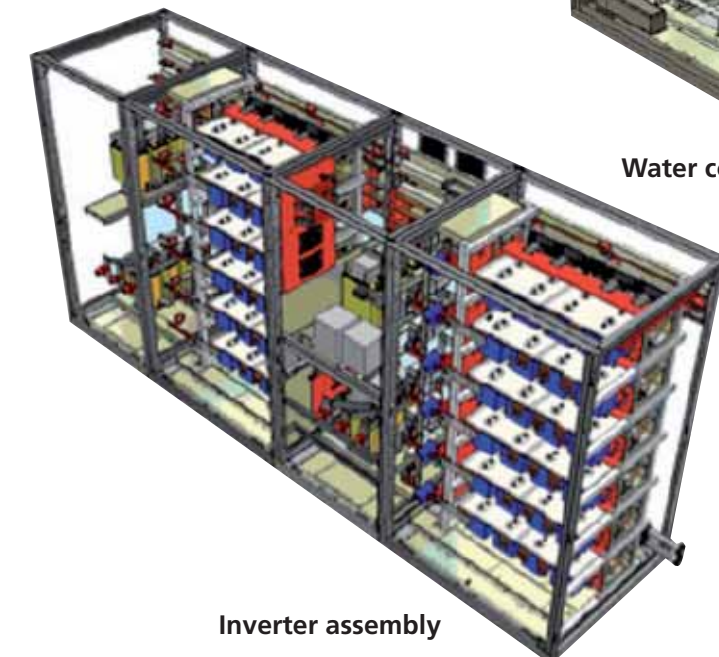

Inverter assembly

Our uncommonly flexible, common control platform

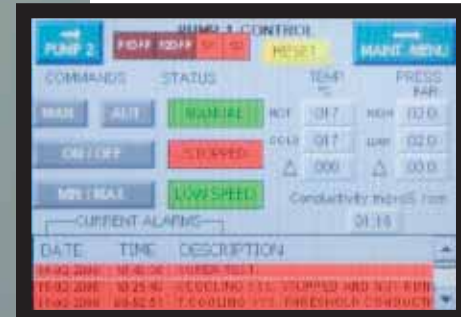

### Versatile HMI is intuitive to the touch

The intuitive HMI is highly versatile and permits the user to personalize the drive settings and controls at the touch of a finger through the front panel mounted touch screen. As an option, the drive can be equipped with an easy-to-use, high-function keypad that allows the same simple performance.

The drive interface is easy to install because it requires a reduced number of connections. The control system has a wide variety of standard communication protocols built into the system for seamless integration into your plant's automation platform.

### Flexibility at your fingertip!

Our control system provides customized reports that can be easily integrated into existing production reports. The software package includes full-diagnostics capabilities and converter data can be consulted on the drive or sent to a master control or supervision system. Our complete line of I/O card types and

extensive library of algorithms and protocols (Profibus, Modbus, C-Bus, Genius, EtherCAT) can be adapted to your changing needs. The control system can be configured to support a single I/O point to hundreds of Digital, Analog, Sequence of Events, and/or Pulse Accumulator input/output points, data trending, historic tracking, alarm processing, etc...

### An important part of your plant maintenance program

A wide range of parameters related to current, voltage, speed, frequency, I/O status, DC Bus voltage, vibration values, temperatures, Auxiliary Supply status, Local/Remote Mode, Trip status are available in order to ensure accurate monitoring of equipment performance, constituting an important part of your predictive and preventive maintenance programs.

### Seamlessly integrates into your production process.



## Performance you can rely on

### Low network harmonics

An ideal frequency converter should control energy flow without generating voltage and current harmonics. Our MV drives ensure excellent power factor line-side in every working condition due to the full-wave rectification using multi-phase diode operation. The harmonic content meets the most stringent requirements for current and voltage harmonic distortion as defined by IEC and NEMA standards.

The harmonic content motor-side is also extremely low thanks to our Pulse Width Modulation (PWM) control that eliminates network harmonics without increasing the drive's complexity.

### Maximum Reliability

At Ansaldo Sistemi Industriali, reliability is a result of low parts count, modular construction, ease of repair/maintenance, global support network, modern tests and our common control system. All these features allow us to supply long lifetime products. At the same time, ASI MV drives increase the lifetime of equipment. The sophisticated algorithms of the torque and speed control result in no current peaks and very low torque ripple on the motor shaft, reducing stress on mechanical and electrical components.

**MTBF 60.000 hours**

### Our system expertise – an additional guarantee

We have complete in-house system capability (motor and converter). Our automation expertise allows us to review overall system requirements to ensure that the variable speed drive and driven equipment deliver system performance.

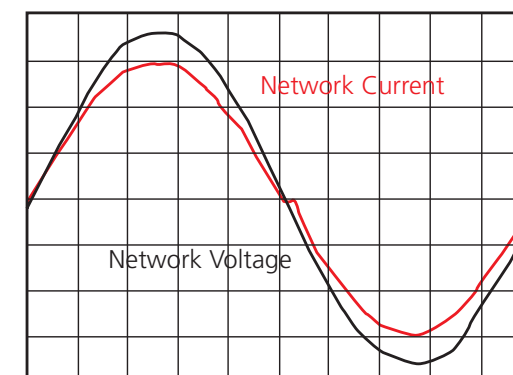

**All our MV drives meet the most stringent IEEE 519 and NEMA requirements.**

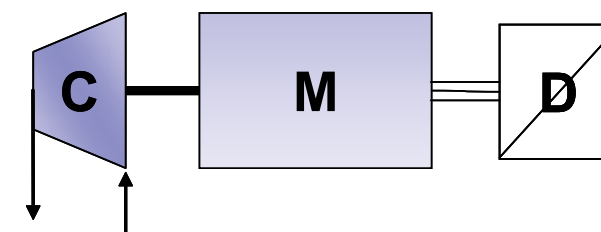

**Motor Current wave form**

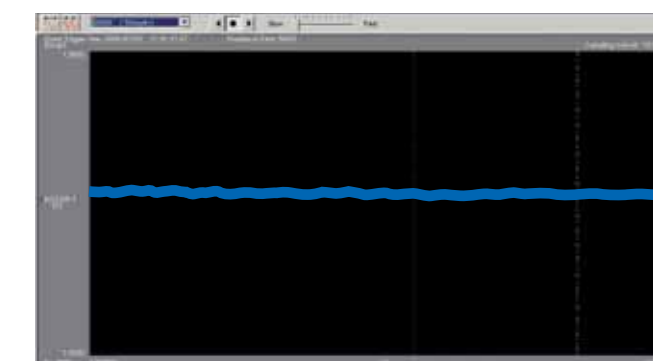
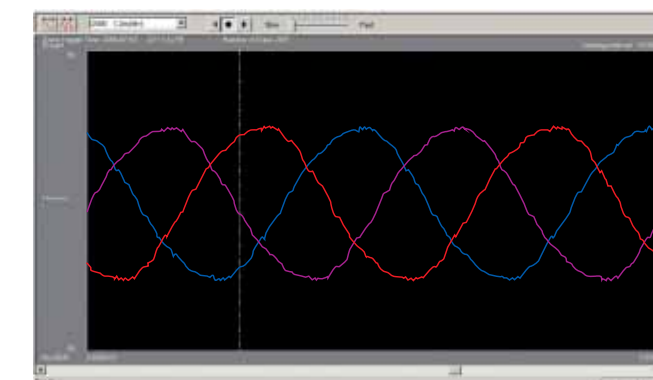

**Torque ripple**

Very safe to use



Our MV drives are configurable - built according to job specification needs using basic standard components. Safety is an important element that we manage and apply to all models and types for each installation and job.

Grounding is vital for safety and should be connected immediately after positioning the equipment at the installation site.

The complete installation procedure guarantees the intrinsic safety of personnel through a simple series of operations covering main circuit breaker, doors and earthing safety switch key interlock.

This last operation ensures that the opening of any cabinet door to access the medium voltage circuits inside is only possible when the main breaker is locked open and the internal safety earth blades switch is locked in the close position, earthing the DC Bus of the drive.

## Very easy to maintain...

The modular design of our machines makes routine maintenance and inspection quick and simple. The drive's control system provides complete diagnostics tools making it possible to program maintenance activities when required. Our use of standard off-the-shelf components means reduced inventory and spare parts requirements. Ansaldo Sistemi Industriali is fully committed to Life Cycle Service and is ready to support customer's needs for upgrades or any other requirement that may arise during the life of our equipment.

## ...even from a distance

Our control software platform also contains an expert system for remote diagnostics. Main functions include: vibration analysis, line parameter analysis (current/voltage), thermal behavior analysis, partial discharge test, bearing health.

# N-Series

Silcovert TN, Silcovert GN

## Ideal for regenerative operation and high demanding performance

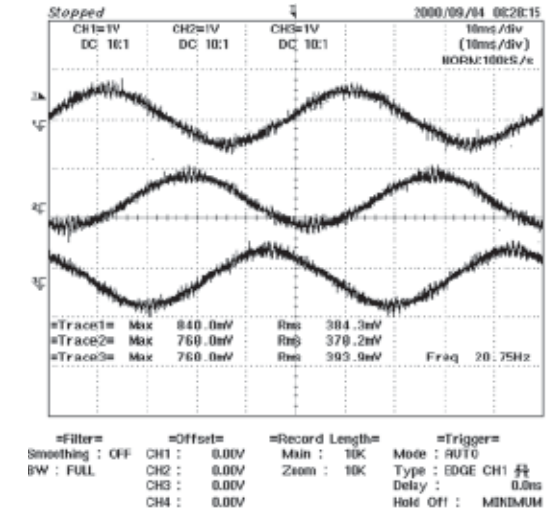
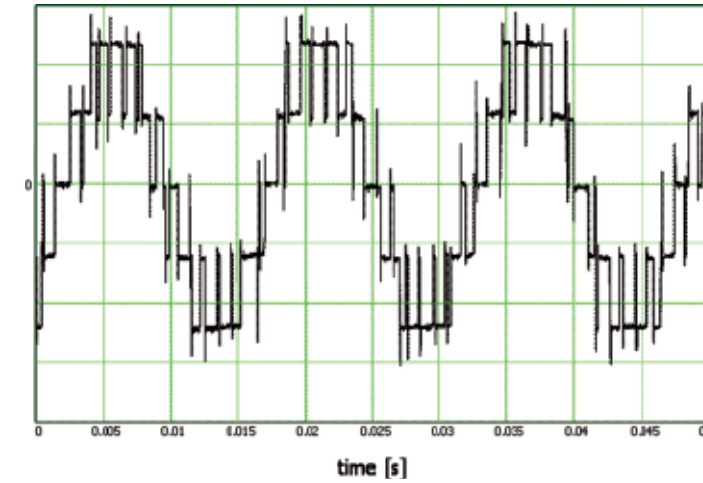

Active Front End (AFE) refers to PWM inverters connected to the supply line able to perform the DC-bus voltage regulation at a fixed value in both motoring and regenerating operation of the motor side converter. The three-level AFE configuration provides ultra high efficiency, controlled power factor, minimum torque ripple and low input and output harmonic content. Fully regenerative operation (with AFE option) provides bi-directional power flow at near unity power factor from zero to full speed eliminating the need for costly VAR compensation systems. This is particularly useful when the drive is used for continuous power generation, for example on wind farms. The drive is able to control the energy produced like any other generator feeding the network. This option increases the redundancy and the security of the network. The AFE drive software has special, built-in control functions that allow operation not only in normal conditions (load sharing with other generators), but also in transient conditions (short-circuits and network failures).



# H-Series

Silcovert TH, Silcovert NH

Ideal for retrofitting to improve efficiency and reduce environmental impact

With a customized retrofit you can achieve increased levels of safety, reliability and efficiency in your plant. We can assist you in the analysis to improve capacity and reduce energy consumption.

Our retrofitting solutions provide you with an optimum return-on-investment, long-time cost reduction thanks to a more efficient and precise control of motors, pumps etc..., reduced down-time and less maintenance.

Our H-series drives are compatible with your existing motor systems, regardless of brand or age. Part of our analysis will address the alternative of installing a completely new variable speed drive system versus that of adding a variable frequency converter to an existing fixed speed motor or re-usable equipment refurbishing. Our goal is to bring new life to your plant through the analysis of existing motors and drives.

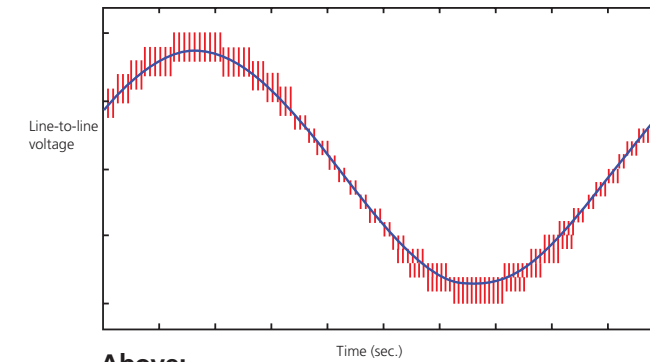

Above:  
our multipulse drives allow clean power operation

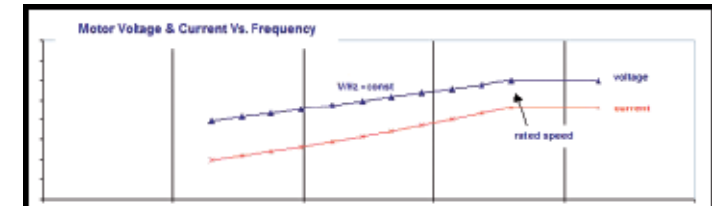
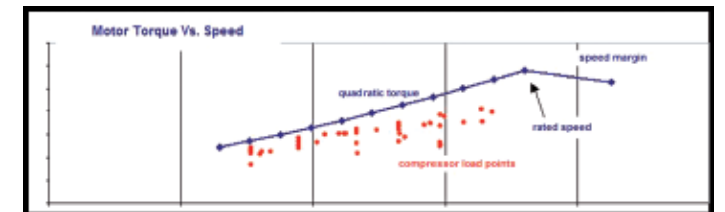
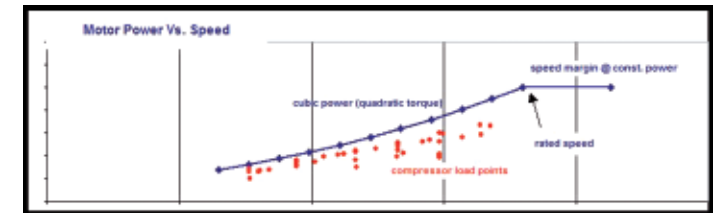

Graphs at right  
A careful analysis of load characteristics allows us to configure the ideal solution for retrofitting.

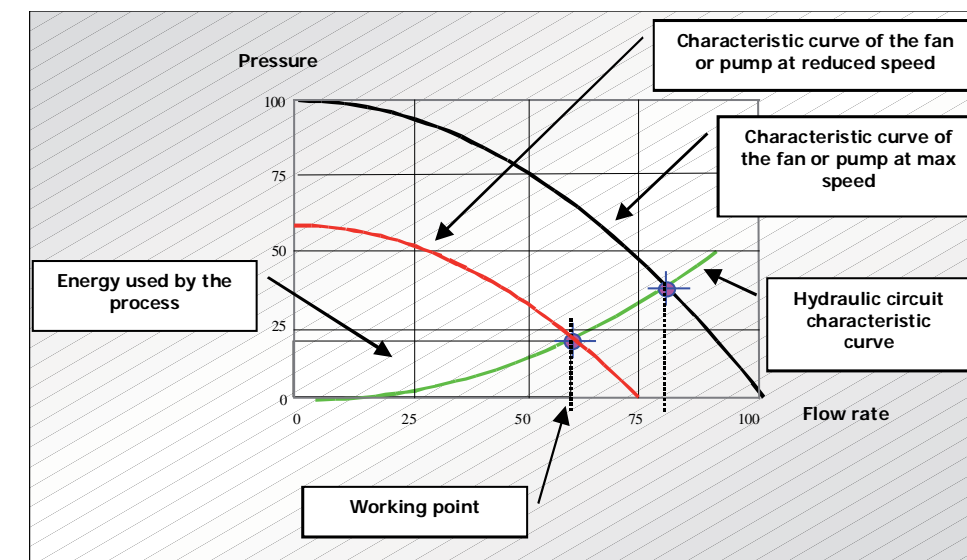
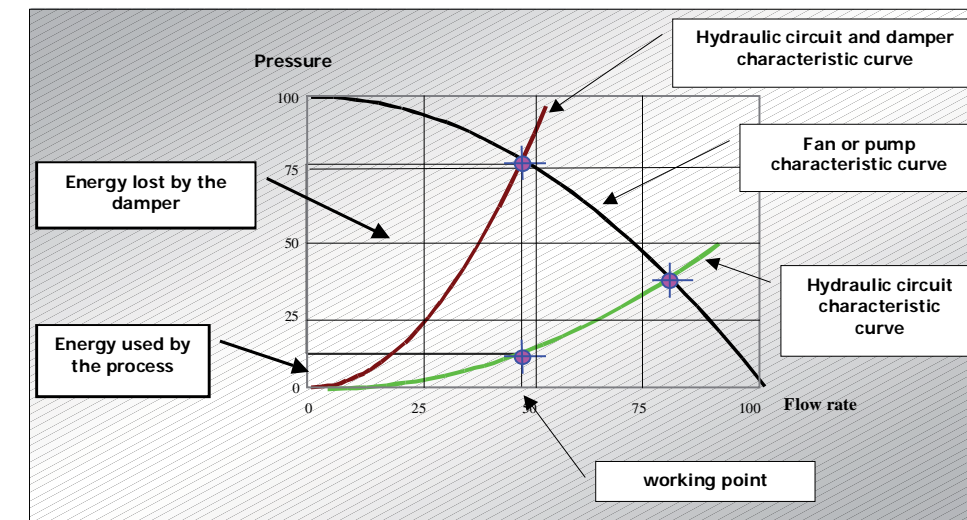

Graphs at left  
show Energy savings achievable by using a variable speed drive.  
**Top graph**  
Energy lost using traditional mechanical control  
**Bottom graph**  
Energy savings with VSD

## The right size for you needs



### **The importance of being adaptable**

Adaptability is an important issue for certain situations, in particular for retrofit and revamping where a new drive has to replace an old one or has to be placed in a predetermined space. In these cases, our custom-engineered drives are the best fitting solution.

### **Finding the right footprint**

For maximum adaptability, our modular design allows us to configure drives with the right footprint for your needs. For example, the drive can be supplied with a separate input transformer that can be placed near the drive or, if space is an issue, the drive can be supplied with an integrated input transformer in a more compact design. We have also developed a series of solutions to provide the drive in a container for a plug-and-play solution that does not affect your current layout. Our container solutions can be equipped with adequate air conditioning systems to meet any environment from the Sahara Desert to the Russian Tundra.



## Product compliance

Standards	IEC EN 61800-3 IEC EN 61800-4 IEC EN 61800-5-1 IEC EN 60204-11 IEC EN 60529
EU directives	98/37/EC and Amendments 89/336/EEC and Amendments

## Environmental limits

Storage Temperature	-20 °C... +70 °C
Operation Temperature	+5...+40 °C; up to 50° C with derating
Permitted Coolant Temperature:	Inlet: +5 ... + 35 °C
Relative Humidity	< 95 %, not condensing
Installation Altitude	< 1000 m a.s.l.
Vibrations:	3M1 class as per IEC 721-3-3: Displacement 2 ... 9 Hz = 0,3 mm Acceleration 9 ... 200 Hz = 1m/s <sup>2</sup>
Noise Level	Air cooled: ≤ 80 dB(A) Water cooled: ≤ 70 dB(A)
Efficiency:	drive efficiency > 98 %

## Control Characteristics

Motor Control Modes:	V/Hz Control Sensorless Vector Control Field Oriented Vector Control (shaft encoder required)
Stationary Operation	Speed static accuracy: ±0,2 % sensorless, speed range 5 to 100 % ±0,01 % with encoder (option)
Dynamic Operation:	Torque response time: 3 ms
Serial Communication:	PROFIBUS, MODBUS, ETHERNET or other on request

## Series N

Drive Quadrants of operation	DFE: 2 or 4 with braking chopper AFE:4	
	Silcovert TN	Silcovert GN
3-phase Input Voltage transformer secondary winding	DFE 12P: 2 x 1800 V ±10 % DFE 24P: 4 x 1800 V ±10 % AFE: 3000 V ±10 %	DFE 12P: 2 x 1800 V ±10 % DFE 24P: 4 x 1800 V ±10 % AFE: 3000 V ±10 %
Power Factor	DFE: ≥ 0,96 AFE: = 1	DFE: ≥ 0,96 AFE: = 1
Input Frequency	50 / 60 Hz ±3 %	50 / 60 Hz ±3 %
3-phase Output Voltage	0...3300 V	0...3300 V
Output Frequency	Normal: 5...70 Hz Extended: 5... 140 Hz	Normal: 10...65 Hz Extended: 10... 100 Hz
Output Power Range	Air Cooling: 1300 - 5200 KVA Water Cooling: 3600 - 7200 KVA	– Water Cooling: 9000 - 24000 KVA (higher power on request)
Shape	PWM	PWM
Cooling Method	Air Cooling, Water Cooling	Water Cooling
Heat Exchanger	Internal water-to-water (std.) External water-to-air or chiller (options)	Internal water-to-water (std) External water-to-air or chiller (option)
Degrees of protection	Air Cooling: IP 31 Water Cooling: IP 42; IP 54 on request	– Water Cooling: IP 42; IP 54 on request

## Series H

Drive Quadrants of operation	DFE: 2	
	Silcovert TH	Silcovert NH
3-phase Input Voltage transformer secondary winding	multipulse	multipulse
Power Factor	≥ 0,96	≥ 0,96
Input Frequency	50 / 60 Hz ±3 %	50 / 60 Hz ±3 %
3-phase Output Voltage	0...4160 - 6000 - 6600 - 7200 V	0...4160 - 6000 - 6600 - 7200 V (12000 V on request)
Output Frequency	250 Hz (std) 330 Hz max. with derating	250 Hz (std) 330 Hz max. with derating
Output Power Range	Air Cooling: 500 - 3000 KVA	Water Cooling: 3600 - 18700 KVA (higher power on request)
Shape	PWM	PWM
Cooling Method	Air Cooling	Water Cooling
Heat Exchanger	External air-to-air	Internal water-to-water (std) External water-to-air or chiller (option)
Degrees of protection	IP 31	IP 42; IP 54 on request

**CORPORATE**

Viale Sarca, 336  
I - 20126 Milano  
Phone +39 02 6445 1  
Fax +39 02 6445 4401  
www.asiansaldo.com

**CUSTOMER SERVICE AND SUPPORT**

Viale Sarca, 336  
I - 20126 Milano  
Phone +39 02 6445 4254  
Fax +39 02 6445 4274  
service@asiansaldo.com

**BUSINESS UNITS & MAIN OFFICES****ITALY****Motors, Generators & Drives**

Via Marconi, 1  
I - 34074 Monfalcone (GO)  
Phone +39 0481 717 111  
Fax +39 0481 717 330

Viale Sarca, 336  
I - 20126 Milano  
Phone +39 02 6445 1  
Fax +39 02 6445 4401

**Industrial Systems & Automation**

Corso Perrone, 11  
I - 16152 Genova  
Phone +39 010 6063 1  
Fax +39 010 6063 773

S.S. 11 - Via Cà Sordis, 4  
I - 36054 Montebello Vicentino (VI)  
Phone +39 0444 449 100  
Fax +39 0444 400 001

**Service**

Viale Sarca, 336  
I - 20126 Milano  
Phone +39 02 6445 4254  
Fax +39 02 6445 4274

**Centro di Ricerca in Elettronica**

di Potenza (CRELP)  
Corso Perrone, 11  
I - 16152 Genova  
Phone +39 010 6063 1  
Fax +39 010 6063 740

**Answer Drives S.r.l.**

S.S. 11 - Via Cà Sordis, 4  
I - 36054 Montebello Vicentino (VI)  
Phone +39 0444 449 268  
Fax +39 0444 449 276  
www.answerdrives.com

For information on the sales office  
or sales representative nearest you  
contact us at: info@asiansaldo.com

**INTERNATIONAL****CHINA**

**ASI Industrial Systems Beijing Co. Ltd.**  
(subsidiary of Ansaldo Sistemi Industriali S.p.A.)  
Room 3206 – 3208 / Beijing Silver Tower  
No. 2 Dong San Huan Bei Road-Chaoyang District  
Beijing People's Republic of China  
tel.: +86 10 6554 4490/91/92  
fax: +86 10 6554 4493

**FRANCE**

**Ansaldo Sistemi Industriali SA**  
Z.I. du Buisson, Rue de la Poudrière  
F-42230 Roche-La-Molière  
tel.: +33 4 77907600  
fax: +33 4 77907629

**GERMANY**

**Ansaldo Sistemi Industriali GmbH**  
Im Teelbruch 104  
D-45219 Essen - Kettwig  
tel.: +49 (0) 2054 104980  
fax: +49 (0) 2054 1049811

**ROMANIA**

**Ansaldo Sistemi Industriali RO**  
235b Darzei II St. - Crevedia, Jud. Dambovită  
137180 Romania  
tel.: +40 374 00 33 54  
fax: +40 757 71 02 04

**RUSSIA**

**AO Ansaldo - VEI**  
Krasnokazarmennaya UI 12  
111250 Moscow, Russia  
tel.: +7 495 3619163  
fax: +7 495 2734391

**Ansaldo Sistemi Industriali – Moscow Office**

Proezd zavoda  
Serp i Molot 6/1  
111250 Moscow – Russia  
tel.: +7 495 6623752  
fax: +7 495 6623750

**THAILAND**

**Ansaldo Sistemi Industriali SpA Thailand Branch**  
Muang Thai-Phatra Office Tower II 24th Fl  
252/119 Rachadaphisek Rd, Huaywang  
Bangkok 10310 Thailand  
tel.: +66 2 6932930  
fax: +66 2 6932934

**USA**

**Anselectric LLC**  
an Ansaldo Sistemi Industriali SpA Company  
4900 Woodway Dr., Suite 970  
Houston, Texas  
77056 USA  
tel.: +1 832 214 4185  
fax: +1 713 583 7775

**VIETNAM**

**ASI Industrial Systems - Representative Office of  
Ansaldo Sistemi Industriali S.p.A.**  
Room 702 – Floor 7th No. 3 Mai Hac De street,  
Hai Ba Trung district - Hanoi  
tel.: +84 4 394 47415  
fax: +84 4 394 47415